

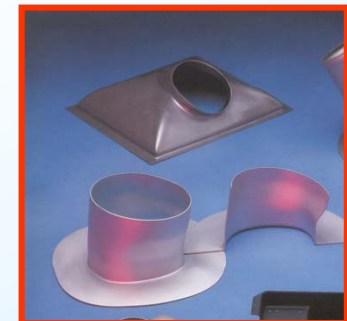

# Introduction aux procédés de fabrication

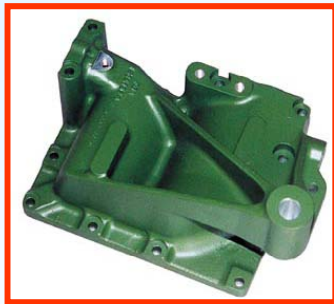

Hocine KEBIR  
Maître de Conférences à l'UTC  
Poste : 7927  
[Hocine.kebir@utc.fr](mailto:Hocine.kebir@utc.fr)



## Rappel : Conseils pour la modélisation des solides 3D

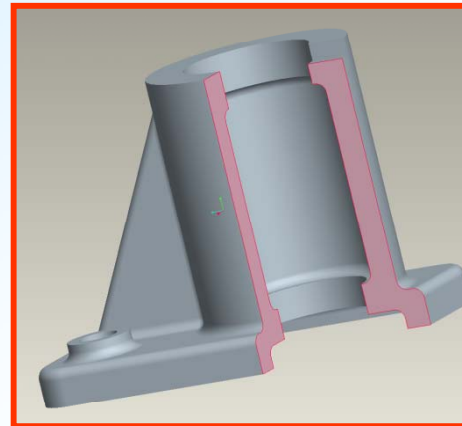
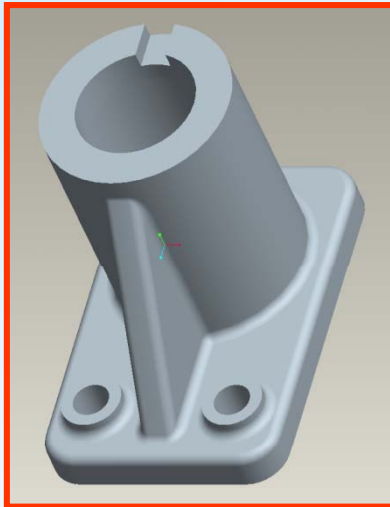

- Respecter la cotation
- Se rapprocher au maximum du procédé de fabrication
- Utiliser le maximum de fonction De base

Nécessité de reconnaître les formes techniques

Rainure

Nervure

Arrondi

Alésage

Bossage

...

Nécessité de connaître les Procédés de fabrication techniques

Usinage

Moulage

...



## Introduction



Avec quels procédés fabrique-t-on ces pièces ?

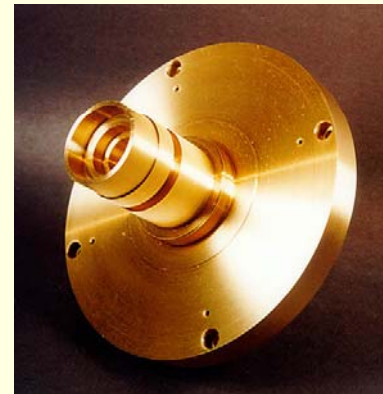

**Objectif du cours**  
Présentation de certains procédés de mise en forme

Pour une description plus détaillée  
voir les UV liées aux méthodes de fabrication : TN03 - TN23

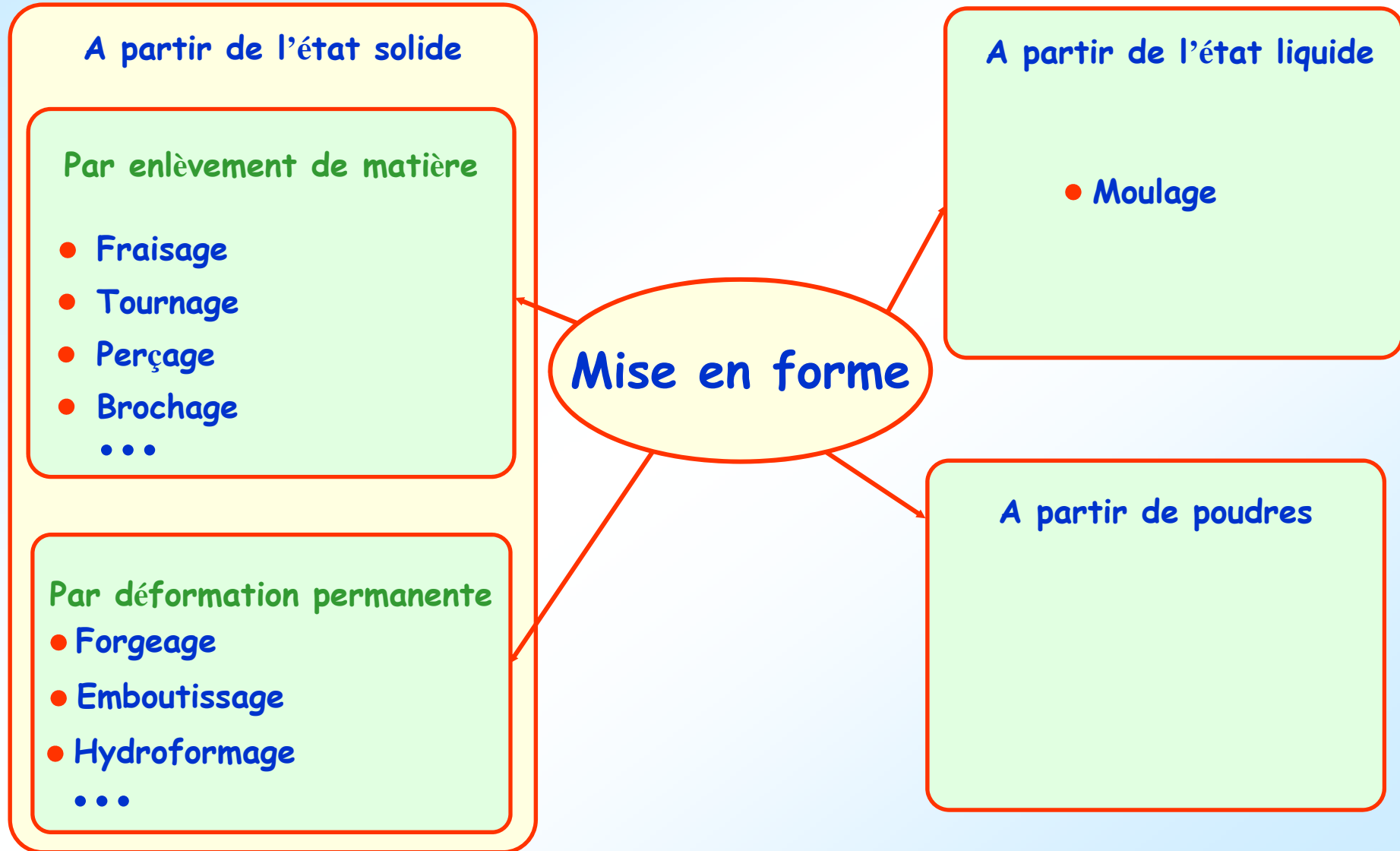



## 1) Mise en forme par enlèvement de matière



Différents outils permettent d'enlever de la matière à une pièce brute

- Usinage par outil coupant : fraisage, tournage, perçage
- Rectification par enlèvement de matière à l'aide des grains abrasifs d'une meule
- Electroérosion par désintégration de la matière à l'aide d'une électrode



## 1) Usinage par outil coupant



Usiner c'est engendrer  
des surfaces par coupe du métal

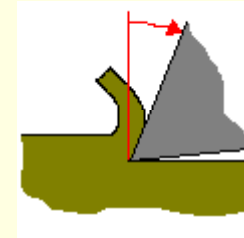

La production des différentes surfaces résulte  
de la conjugaison de deux mouvements

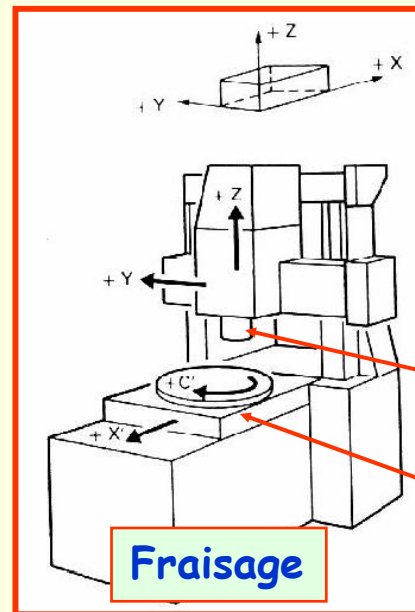

Mouvement de coupe (qui est rapide)

Mouvement d'avance (qui est lent)

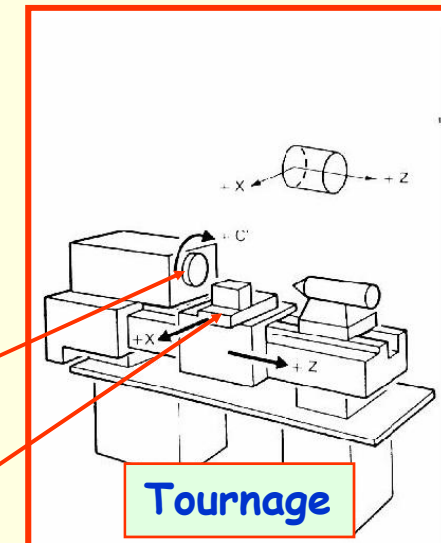



# Fraisage







## Fraisage



### Fraiseuse

- C'est un procédé d'usinage de formes globalement prismatiques.
- Il utilise des outils de coupe à dents multiples de forme circulaire appelés fraises.

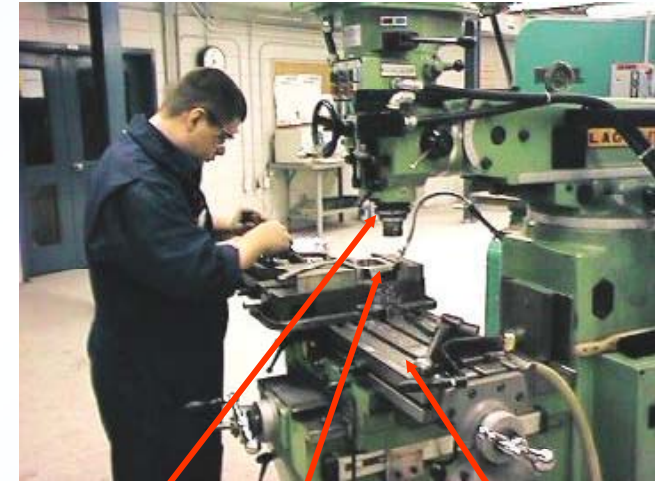

Fraise

Pièce

Table

- La fraise est animée d'un mouvement circulaire uniforme (mouvement de coupe), Son axe est généralement fixe.
- La pièce est solidaire d'une table qui est déplacée en fonction de l'usinage à réaliser (mouvement d'avance).







## Fraisage



Vidéo : Exemple d'usinage sur une fraiseuse





## Les opérations de fraisage



Les opérations "en bout" :  
La surface usinée est sous la fraise.

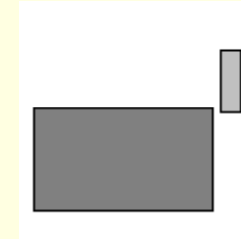

Les opérations "en roulant" :  
La surface usinée est tangente à la génératrice de la fraise.  
C'est donc le profil de la fraise qui va déterminer la forme.  
Le profilage, le détournage, l'usinage de poche,  
le contournage sont des opérations "en roulant".

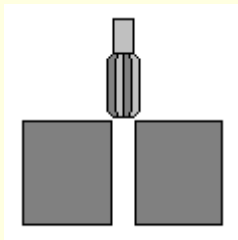
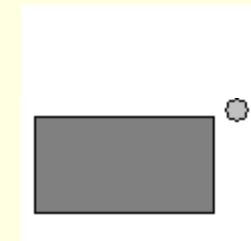

Alésage

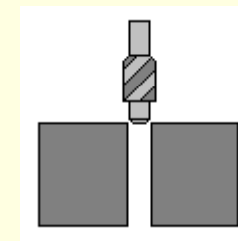

Lamage



## Les outils pour le fraisage

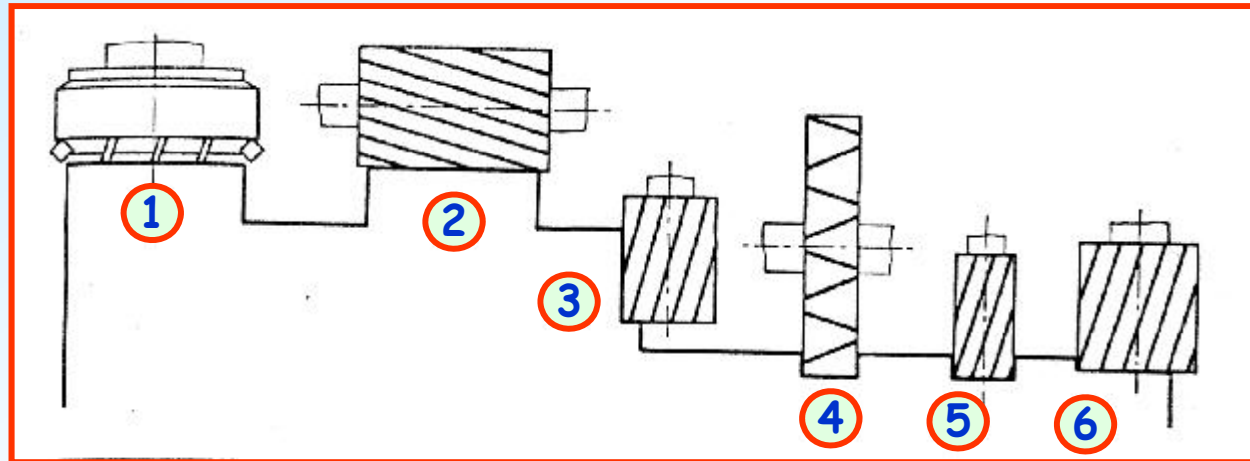

- 1- Surfaçage de face par une fraise à surfacer 1 taille
- 2- Surfaçage de profil par une fraise à surfacer 1 taille et fraise 2 taille
- 3- Surfaçage et dressage combiné avec prédominance d'un fraisage de profil
- 4- Rainurage par une fraise 3 tailles
- 5- Rainurage par une fraise 2 tailles
- 6- Surfaçage et dressage combiné avec prédominance d'un fraisage de face



## Fraisage : Exemples

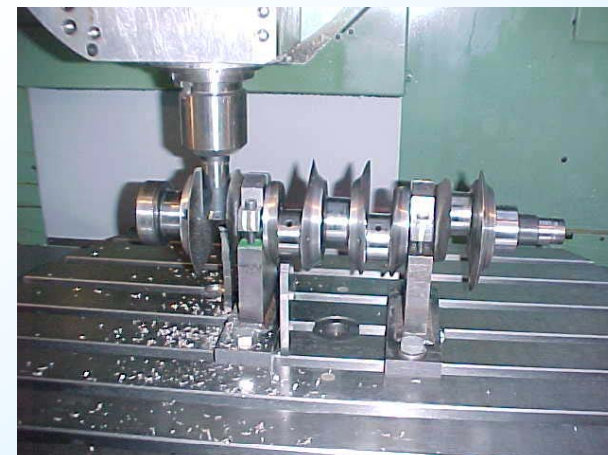
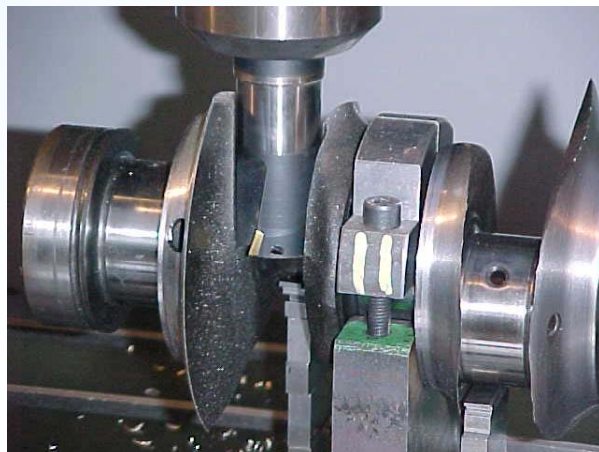
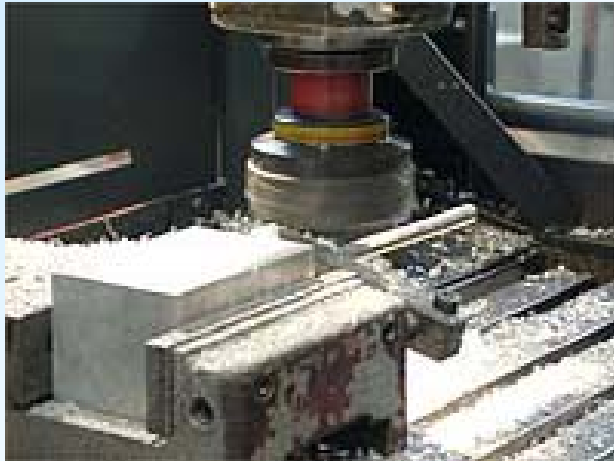



## Pièce à modéliser



Comment réalise-t-on cette pièce sur PROE?



Comment cette pièce est-elle fabriquée ?



## Fraisage : Exemple



Pièces brutes



Fraisage dans la masse



Contournage, surfacage, alésage,  
rainurage, perçage, taraudage



Usinage complet



Pièce finie après la rectification





## Fraisage



Vidéo : Fraisage dans la masse





## Fraisage



Vidéo : Alésage





## Fraisage



Vidéo : Changement d'outillage





## Fraisage



Vidéo : Contournage





# Fraisage



Vidéo : Rainurage





## Fraisage



Vidéo : Rectification







# Tournage





## Tournage



Ce procédé d'usinage permet d'obtenir des formes de révolution extérieures ou intérieures, à l'aide d'outil généralement à tranchant unique



Outil

Porte-outil

Pièce



## Tournage



Vidéo : Exemple d'usinage sur un tour





# Tournage

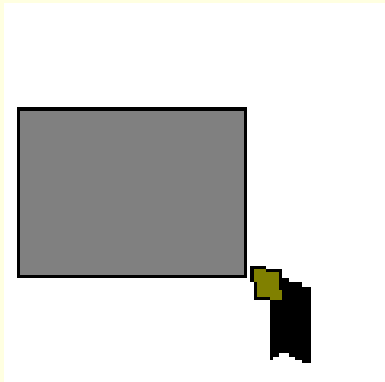

## Chariotage

l'outil se rapproche plus de la broche qu'il ne se déplace vers l'axe de rotation

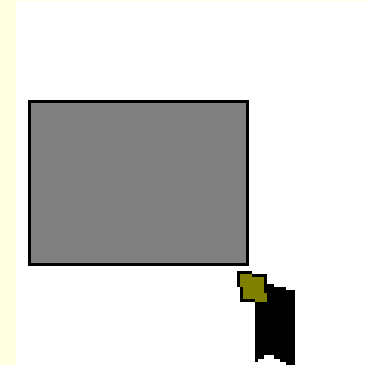

## Dressage

l'outil se rapproche plus de l'axe de rotation qu'il ne se déplace vers la broche

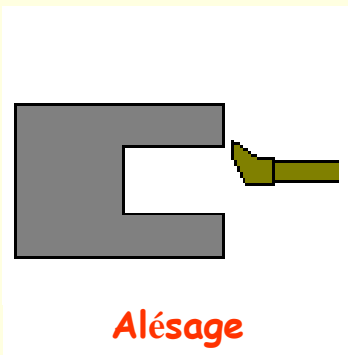

## Alésage

**Copiage**  
obtention d'une pièce de révolution dont la génératrice est un profil composé complexe

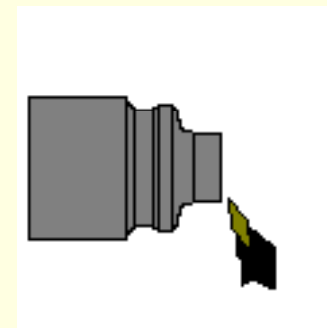



## Les outils pour le tournage



- 1- Outil à saigner
- 2- Outil à charioter droit
- 3- Outil à retoucher
- 4- Outil pelle
- 5- Outil à retoucher
- 6- Outil à fileter
- 7- Outil coudé à charioter
- 8- Outil couteau
- 9- Outil à dresser d'angle
- 10- Outil à dresser les faces
- 11- Outil à chambrer
- 12- Outil à aléser
- 13- Outil à fileter intérieurement
- 14- Outil à aléser-dresser

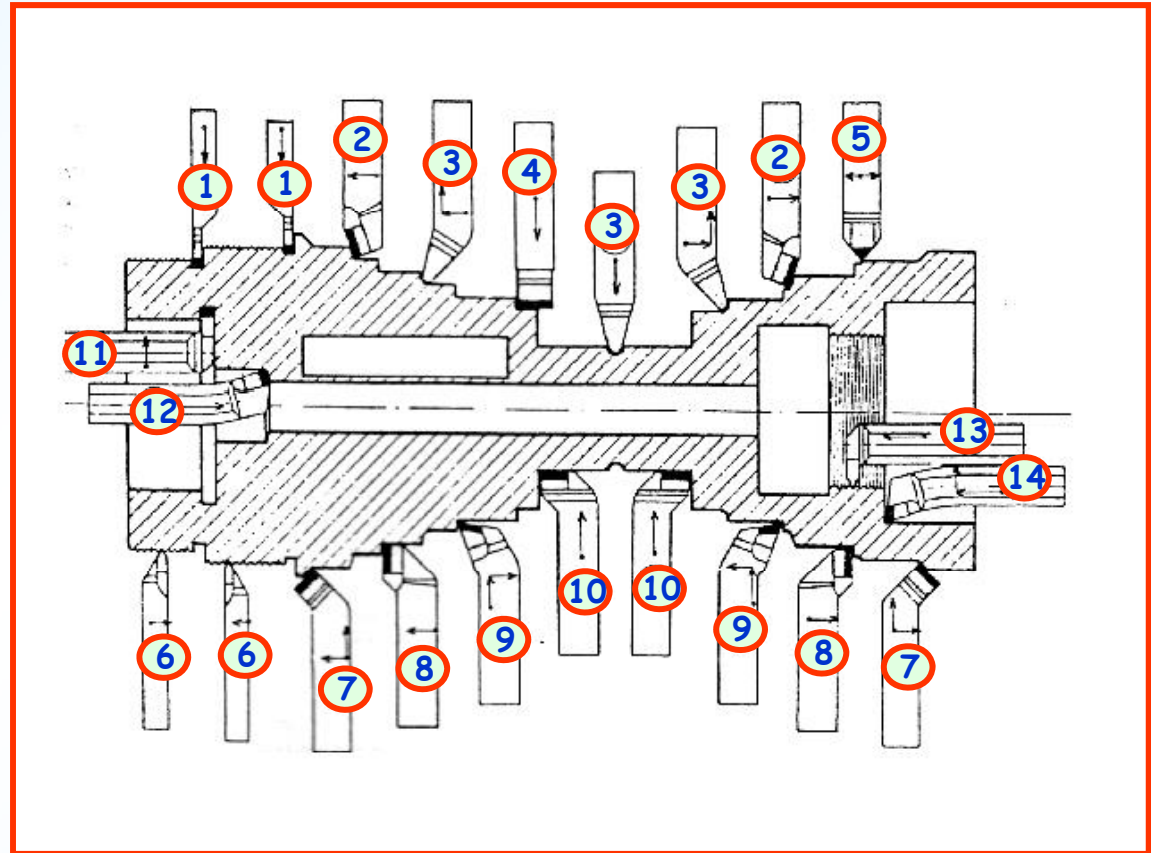





## Tournage : Exemples

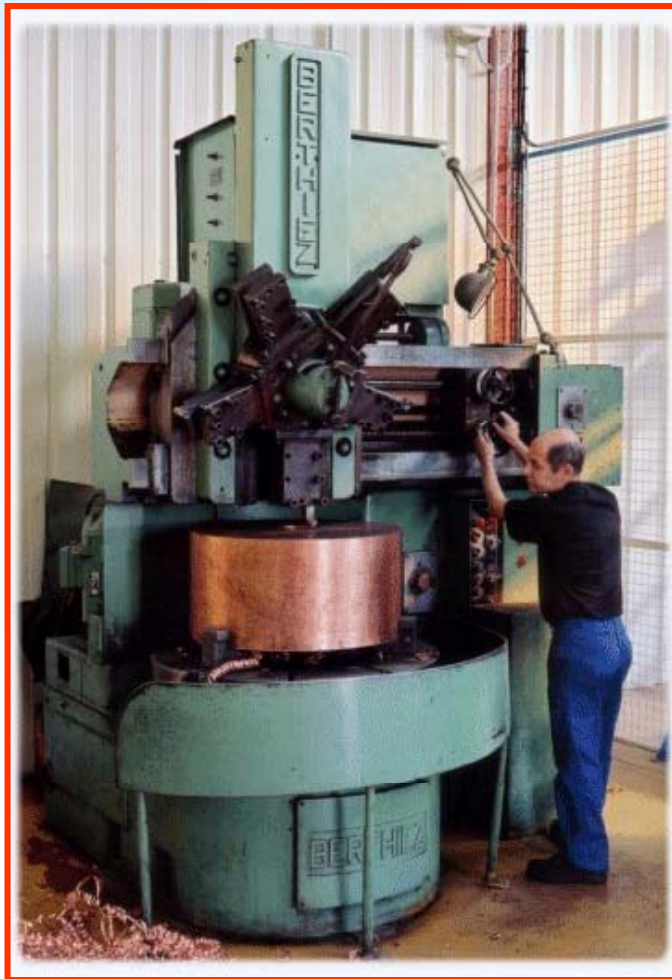





## Tournage : Exemple

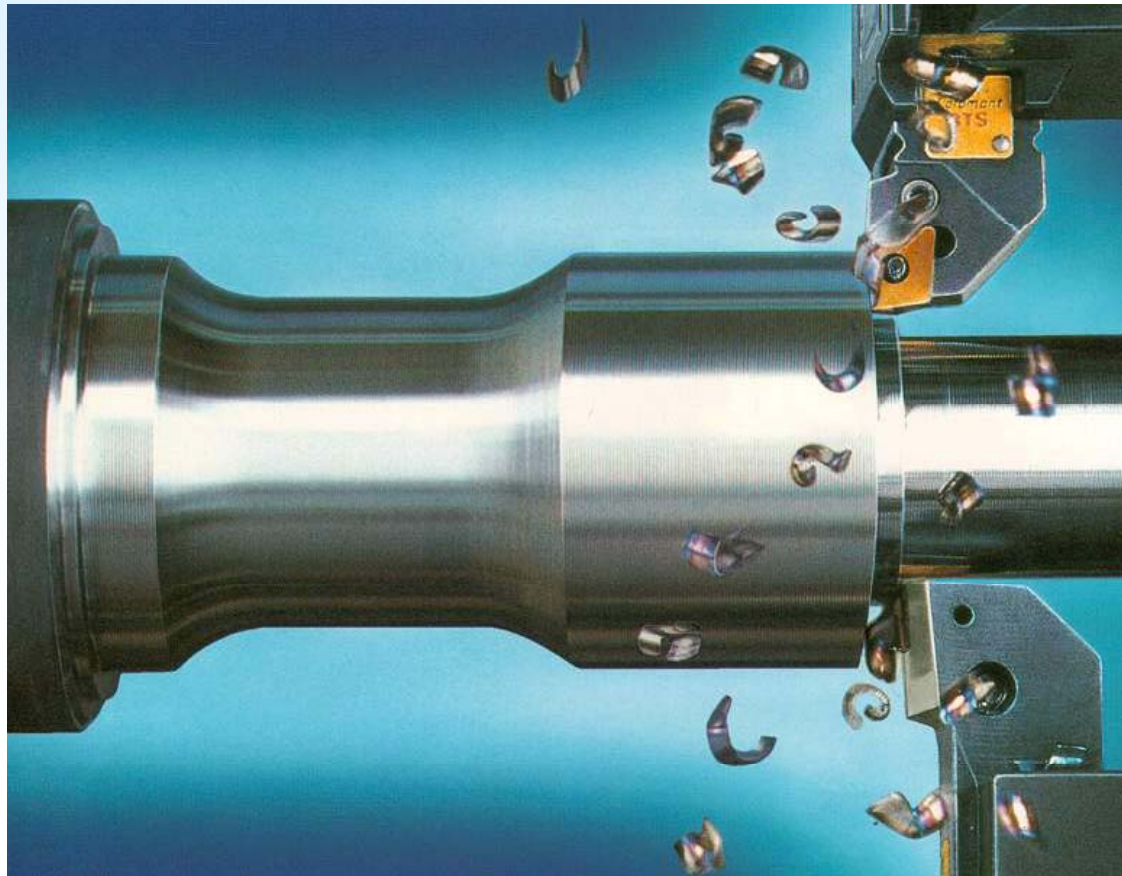

Deux outils de coupe en même temps



## Tournage (Exemple)



Comment réaliser cette pièce sur PROE?



Roue d'engrenage

Comment cette pièce est elle fabriquée ?



# Tournage



Pièce brute



Tournage



Taillage par fraise mère



## Tournage



Vidéo : Exemple d'usinage sur un tour





## Tournage



Vidéo : Exemple d'usinage sur un tour







# Perçage





## Perçage



Le perçage est une opération qui permet la réalisation de trous cylindriques en pleine matière à l'aide d'un outil appelé foret

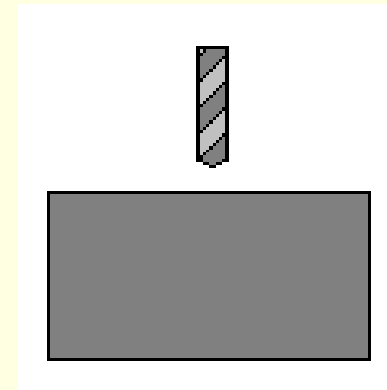



## Exemple d'autre technique d'usinage



Vidéo : Taillage d'engrenage conique





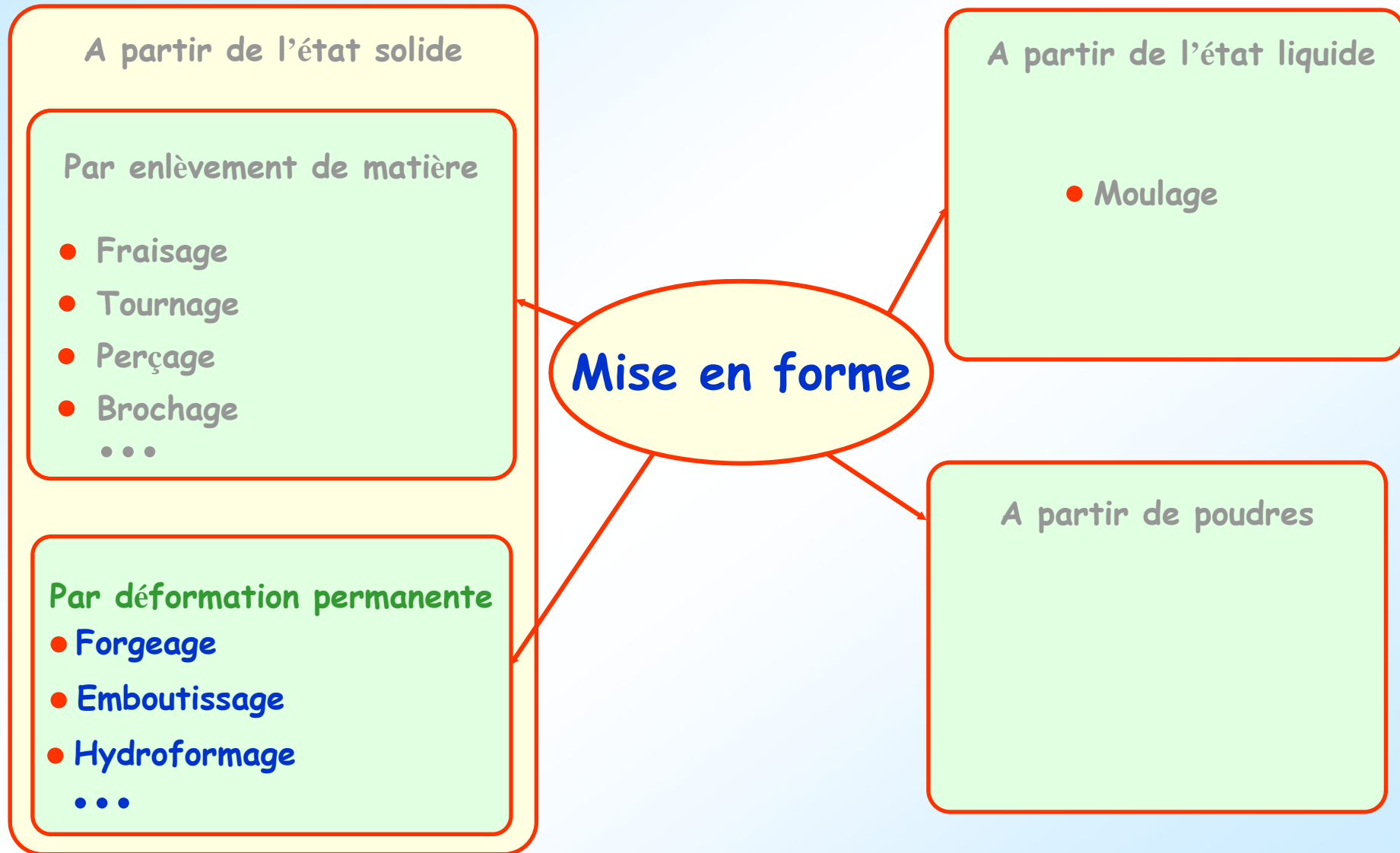



# Emboutissage





## Emboutissage



- Cette technique permet l'obtention de corps creux à partir d'un flan découpé dans une feuille.
- Le flan est déformé entre une matrice et un poinçon.
- L'outillage (poinçon, matrice, ...) est monté sur une presse

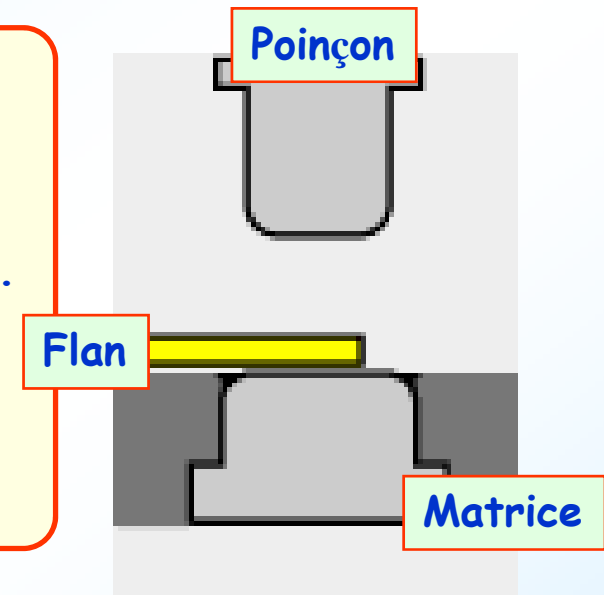

Ce procédé s'applique aux pièces de grande série (automobile, électroménager, ...). Ces pièces étant généralement de faible épaisseur, l'emboutissage s'effectue à froid



Presse



# Emboutissage : exemples de pièces embouties





# Hydroformage

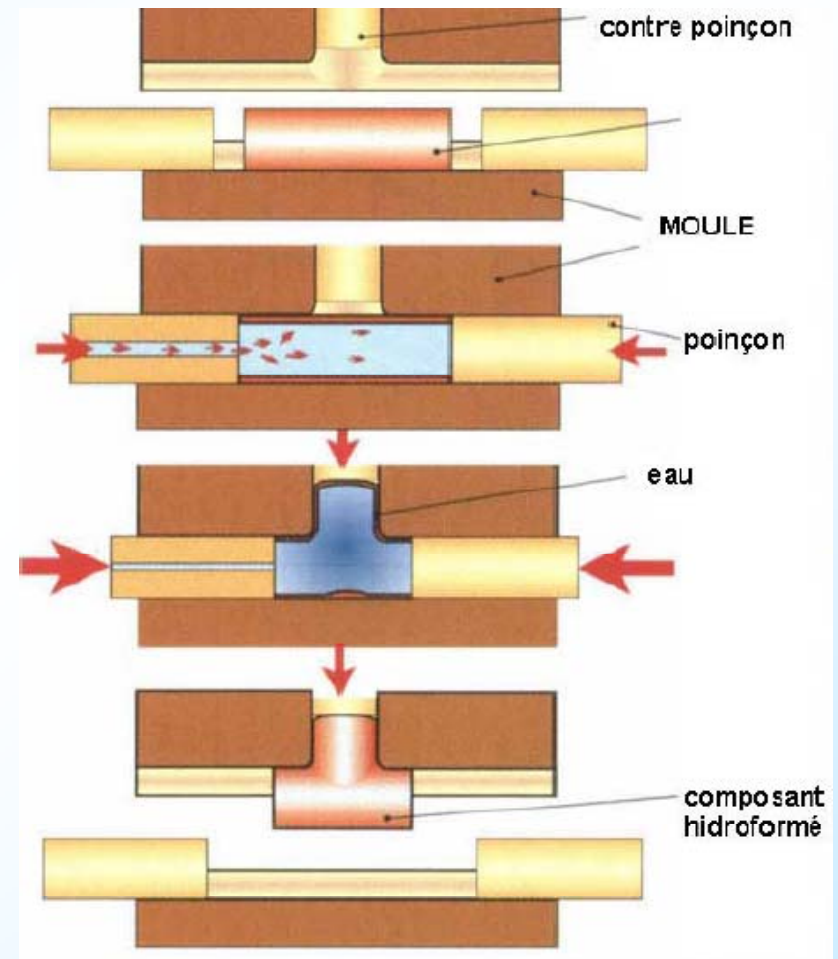

Principe



## Exemple







## Procédé de mise en forme

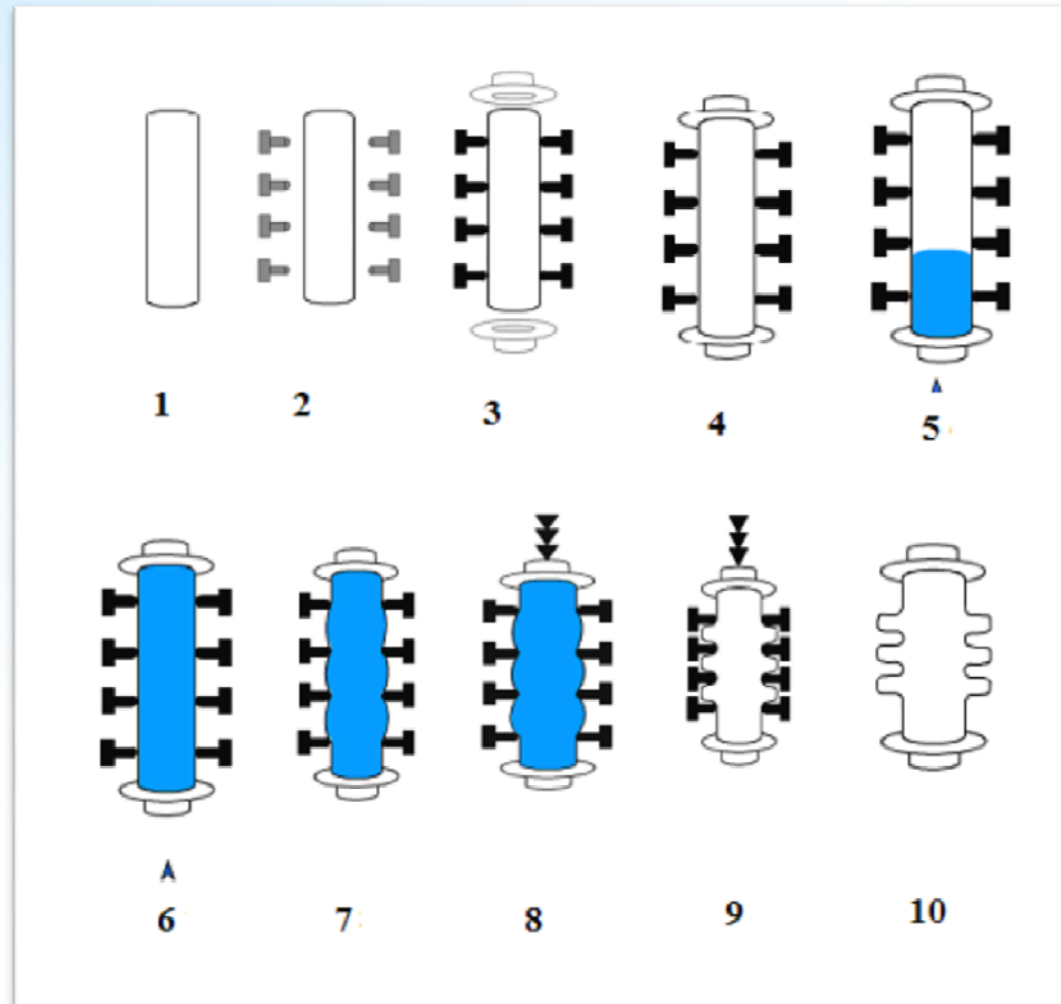

Hydrauformage





# Simulation du procédé de mise en forme (Contraintes résiduelles)

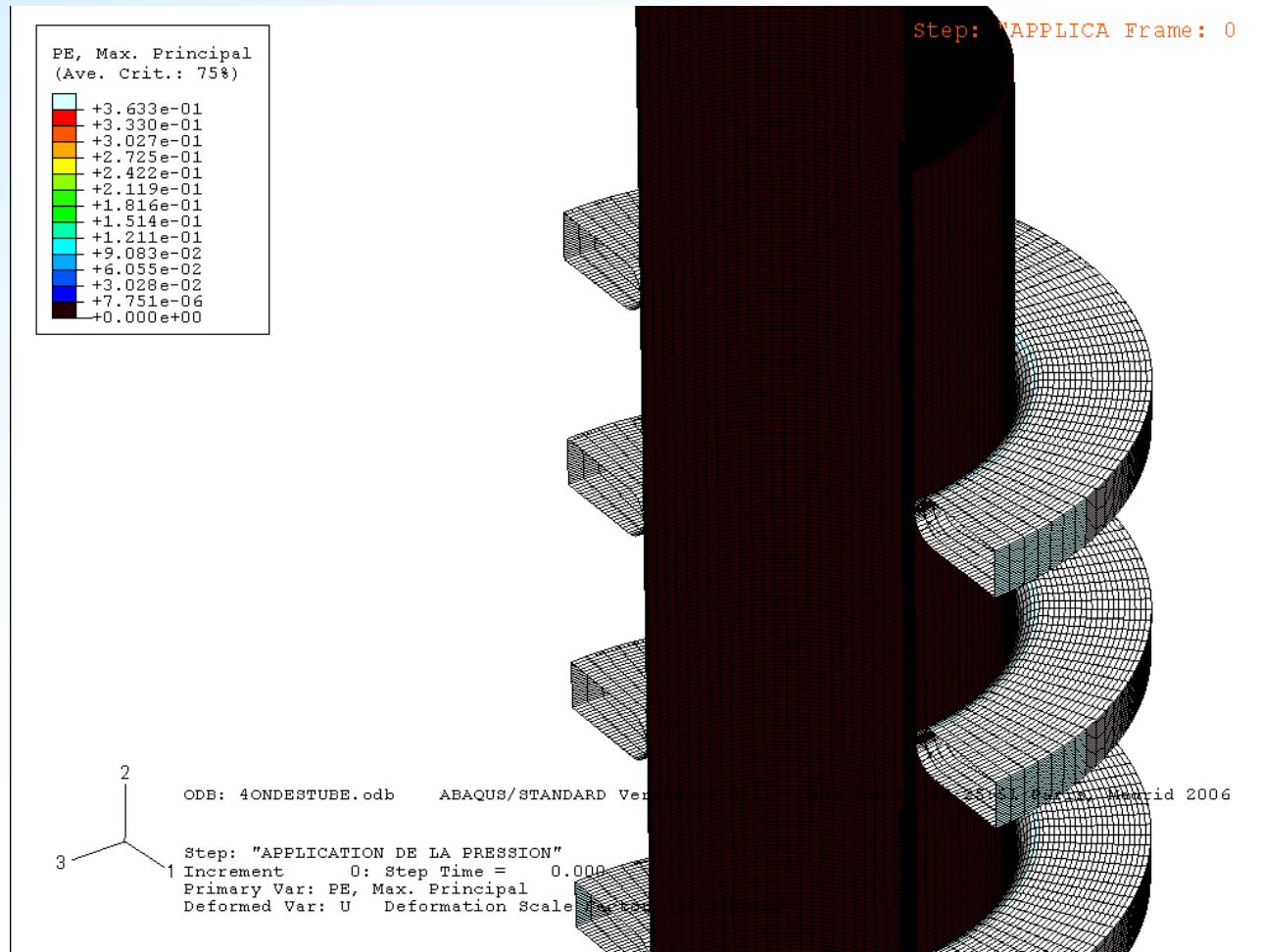



# Forgeage



Exemple de pièce forgée à chaud : vilebrequin



## Principe

- Un lopin (morceau cisailé dans une barre laminée) est chauffé à température convenable.
- Il est ensuite déformé entre deux matrices en acier portant des gravures correspondant aux formes intermédiaires (ébauches) puis définitives à obtenir.
- Ces matrices sont montées sur un marteau pilon ou sur une presse à forger.
- Sous l'action des forces de pression, le métal se déforme et remplit les empreintes.



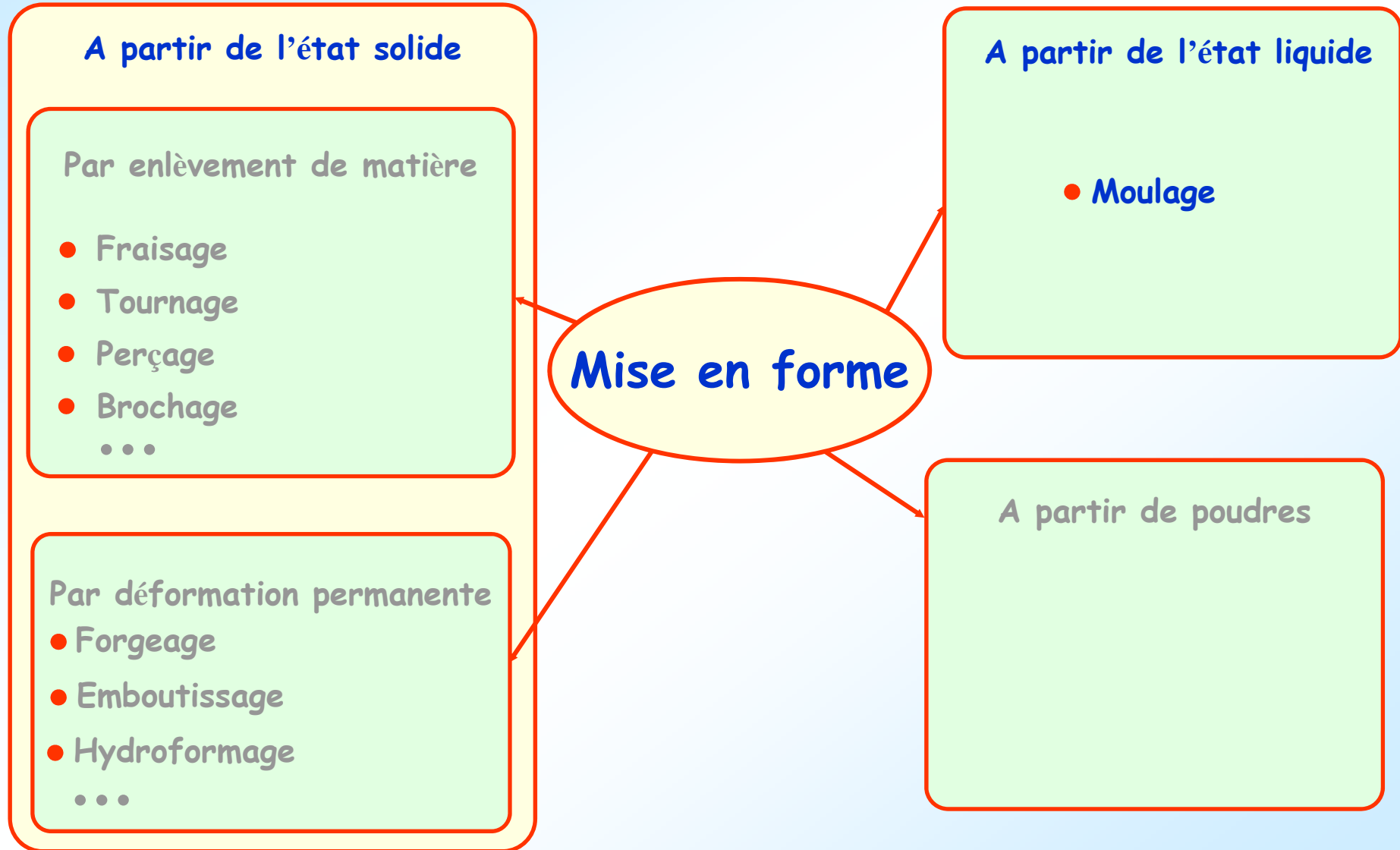



Mise en forme à partir de l'état liquide



# Moulage

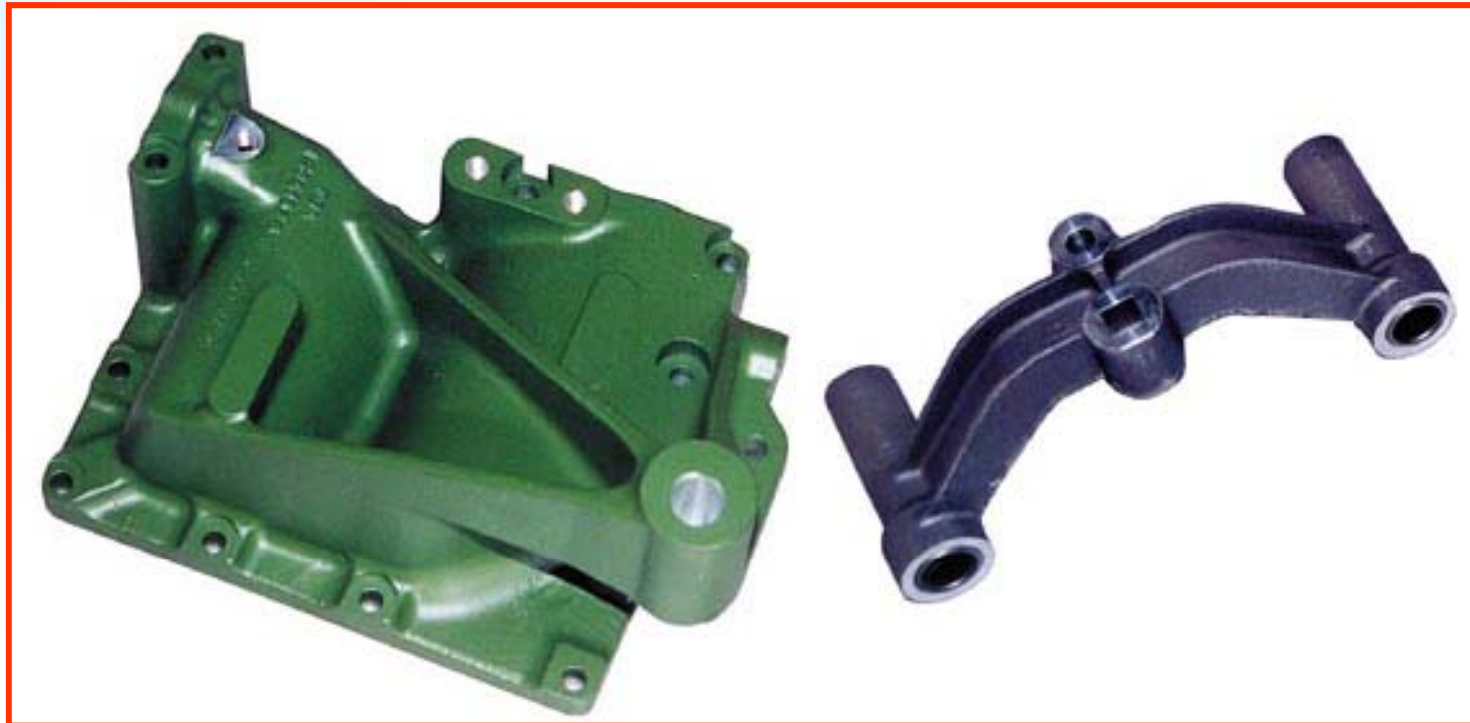



## Moulage



Le moulage permet de réaliser des pièces pleines ou creuses, pouvant présenter des formes très compliquées, en remplissant de métal liquide ou de polymère pâteux une empreinte appelée moule.



moule



métal fondu







## Moulage



Après solidification et refroidissement, on obtient la forme et la dimension souhaitée



On réalise ainsi une sensible économie de matière et on réduit considérablement voire totalement les usinages d'où une économie substantielle (moyenne et grande séries)





## Moulage : exemples



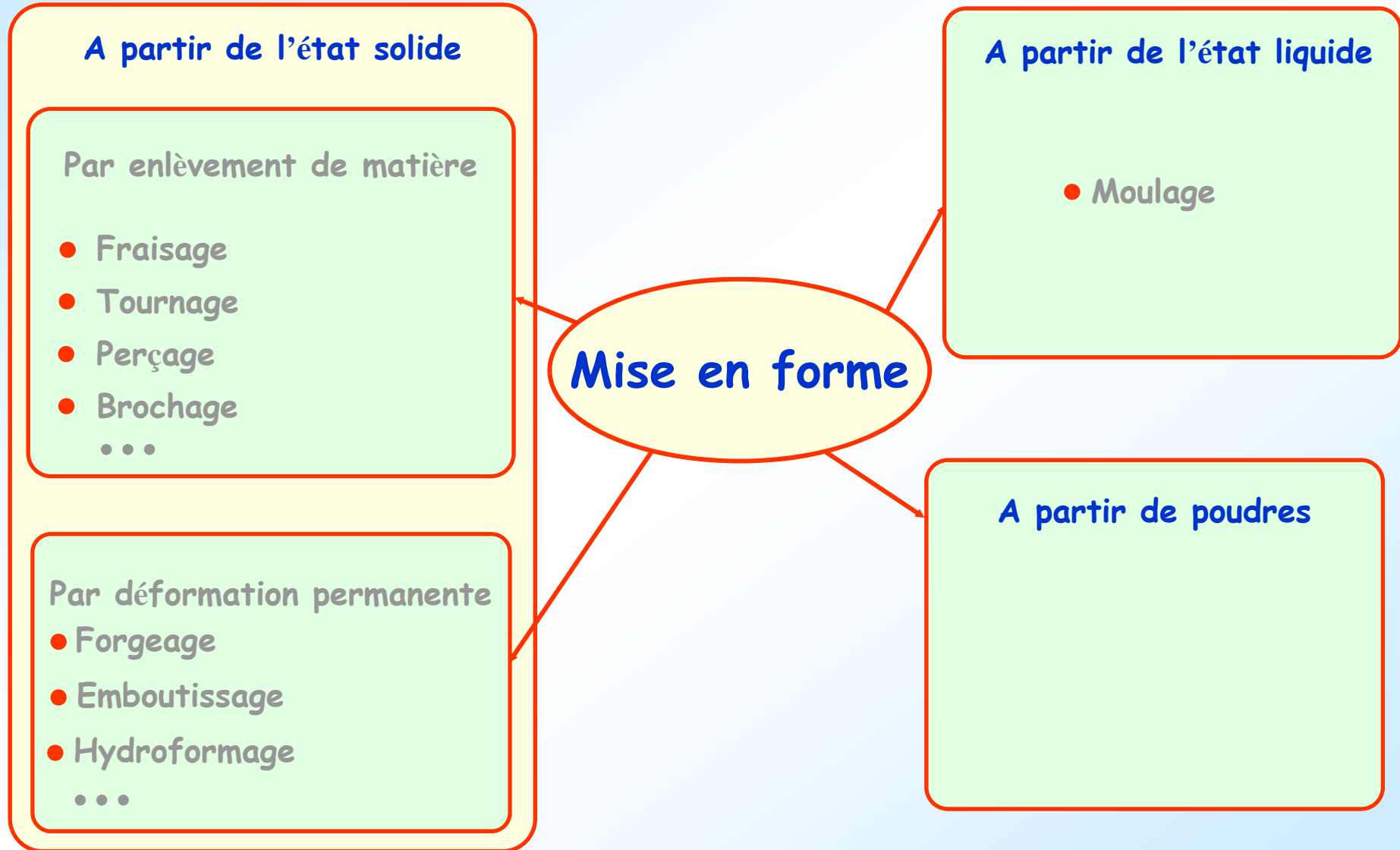



# Poudres





## Mise en forme de poudres



1

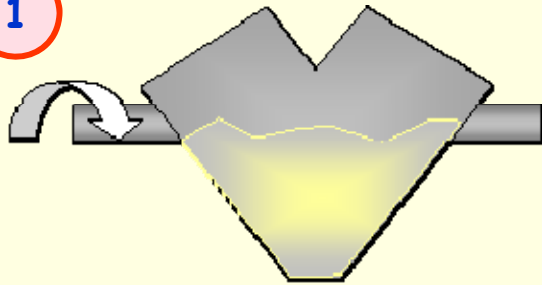

Mélange des constituants  
(poudre et additifs)

3

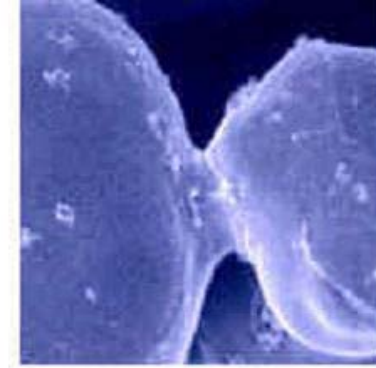

Frittage ou consolidation  
à haute température

2

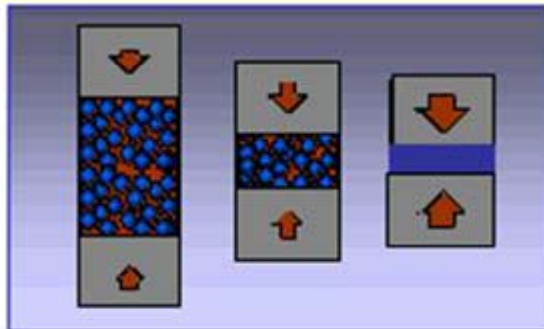

Compression de la poudre

4



Pièces finales